

TCS2P125

Automatic Transfer Switch Control Unit for 1 Phase System Operation Manual



Single Phase 2P 125 Amp Rated Voltage 250 Vac
Patent Number : U.S. Pat. No. 9,257,871 B1



KUTAI ELECTRONICS INDUSTRY CO., LTD.

TEL : +886-7-8121771

FAX : +886-7-8121775

Website : www.kutai.com.tw

Headquarters : No.3, Ln. 201, Qianfu St., Qianzhen Dist., Kaohsiung City 806037, Taiwan

ISO 9001
ETC

TABLE OF CONTENTS

| Section | Page |
|--|-------------|
| SECTION 1 : INTRODUCTION | |
| 1.1 Safety Precautions | 3 |
| 1.2 Products Overview | 3 |
| SECTION 2 : HARDWARE DESCRIPTION | |
| 2.1 Front Panel | 4 |
| 2.2 TCS2P125 Dimensions | 5 |
| 2.3 Panel Cut-Out For The TC-V2 | 5 |
| SECTION 3 : FUNCTION DESCRIPTION | |
| 3.1 General | 6 |
| 3.2 TDNE Setting | 6 |
| 3.3 TDEN Setting | 6 |
| 3.4 TDEC Setting | 6 |
| 3.5 TDES Setting | 6 |
| 3.6 TD-OFF Setting | 6 |
| 3.7 Plant Exerciser | 6 |
| 3.8 Over / Under Voltage Sensing | 6 |
| 3.9 Transfer Failure | 6 |
| SECTION 4 : OPERATION | |
| 4.1 General | 7 |
| 4.2 AUTO Mode | 7 |
| 4.3 TEST Mode | 7 |
| 4.4 Programming Mode | 7 |
| 4.5 AC Voltage Display Adjustment | 7 |
| 4.6 Specification Summary | 7 |
| 4.7 System Setting Reference Table | 8 |
| SECTION 5 : INSTALLATION INSTRUCTIONS | |
| 5.1 General | 9 |
| 5.2 Installation On The Plate | 9 |
| 5.3 TC-V2 Installation On The Door Panel | 10 |
| SECTION 6 : TYPICAL WIRING | |
| 6.1 TCS2P125 Standard Wiring Diagram | 11 |

SECTION 1 : INTRODUCTION

1.1 Safety Precautions (WARNINGS)

This manual covers the installation, operation and maintenance of the TCS2P125 Automatic Transfer Switch. It is intended for qualified personal only.

WARNING
High Voltages Can Kill.

1.2 Products Overview

The TCS2P125 automatic transfer switch consist of two parts the TS2P125 switch and the TC-V2 electronic control unit :

1.2.1 TS125 Features

The contacts on the Kutai TS2P125 transfer switch are class PC, this means that it is capable of making and withstanding short circuits but is not intended for breaking short circuit current.

- Rated operating Voltage : 250 Vac
- Rated operating Current : 125 Amps
- Number of poles : 2P
- Coil operating voltage : 110 / 220 Vac +/- 20%
- Compact size, light weight and low power consumption.
- Electrically operated and mechanically held.
- Manufactured using UL 94V-0 plastics.
- Adjustable time delay in OFF position when transferring.
- Designed for cell-phone repeaters, and many industrial and home ATS applications.

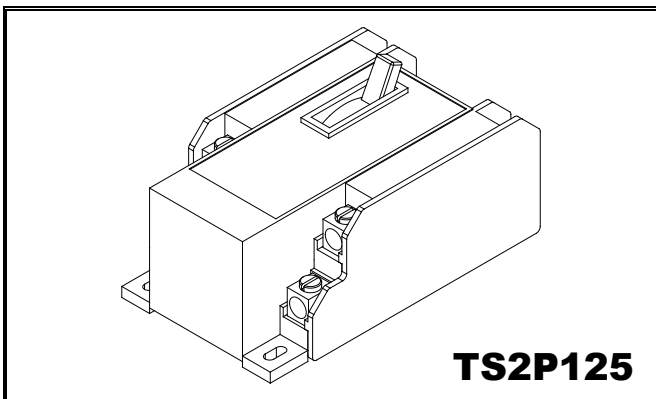

1.2.2 TC-V2 Digital Controller

The TC-V2 digital control unit offers programming flexibility to customize the ATS to different customer requirements.

The Controller :

- Monitor normal source for full phase over and under voltages.
- Monitor emergency source for single phase over and under voltages.
- Normal & emergency source voltage and frequency parameter display.
- TDEN, TDNE, TDEC and TD-OFF real time countdown display.
- Permit testing the transfer switch from the control panel.
- Permit system testing the transfer switch with or without load from the front panel.
- Built-in 1 to 4 weeks exerciser timer.
- Permit customer plant exerciser test with / without load on a preset period.
- Safely store customer / factory settings in permanent memory.
- Shows status and failure alarm LED's on the front panel.
- No need for PC connection and programming software. All settings can be made on site.
- Controller can be installed next to switch or separately on an enclosure panel.

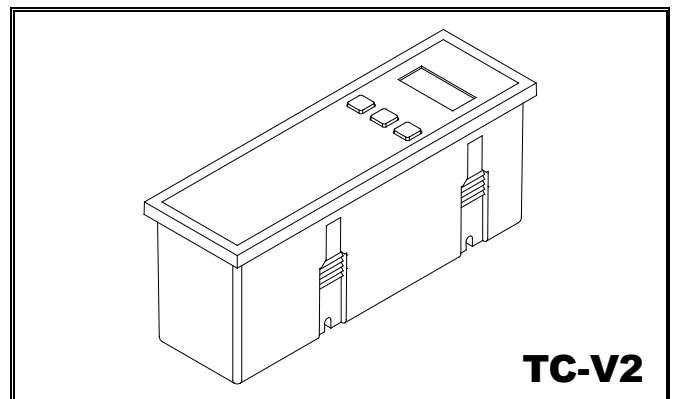

SECTION 2 : HARDWARE DESCRIPTION

2.1 Front Panel

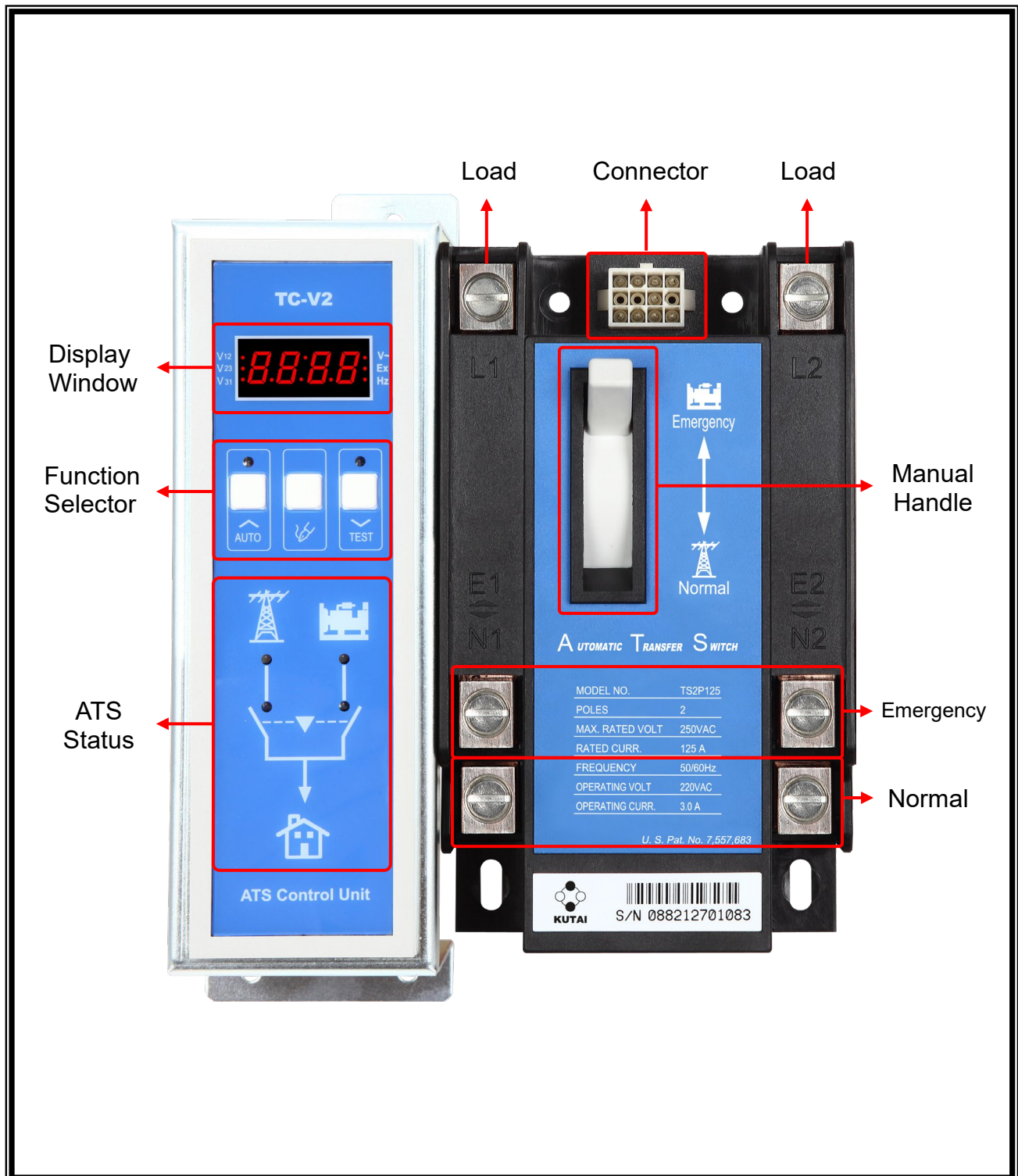

2.2 TCS2P125 Dimensions (Unit : mm)

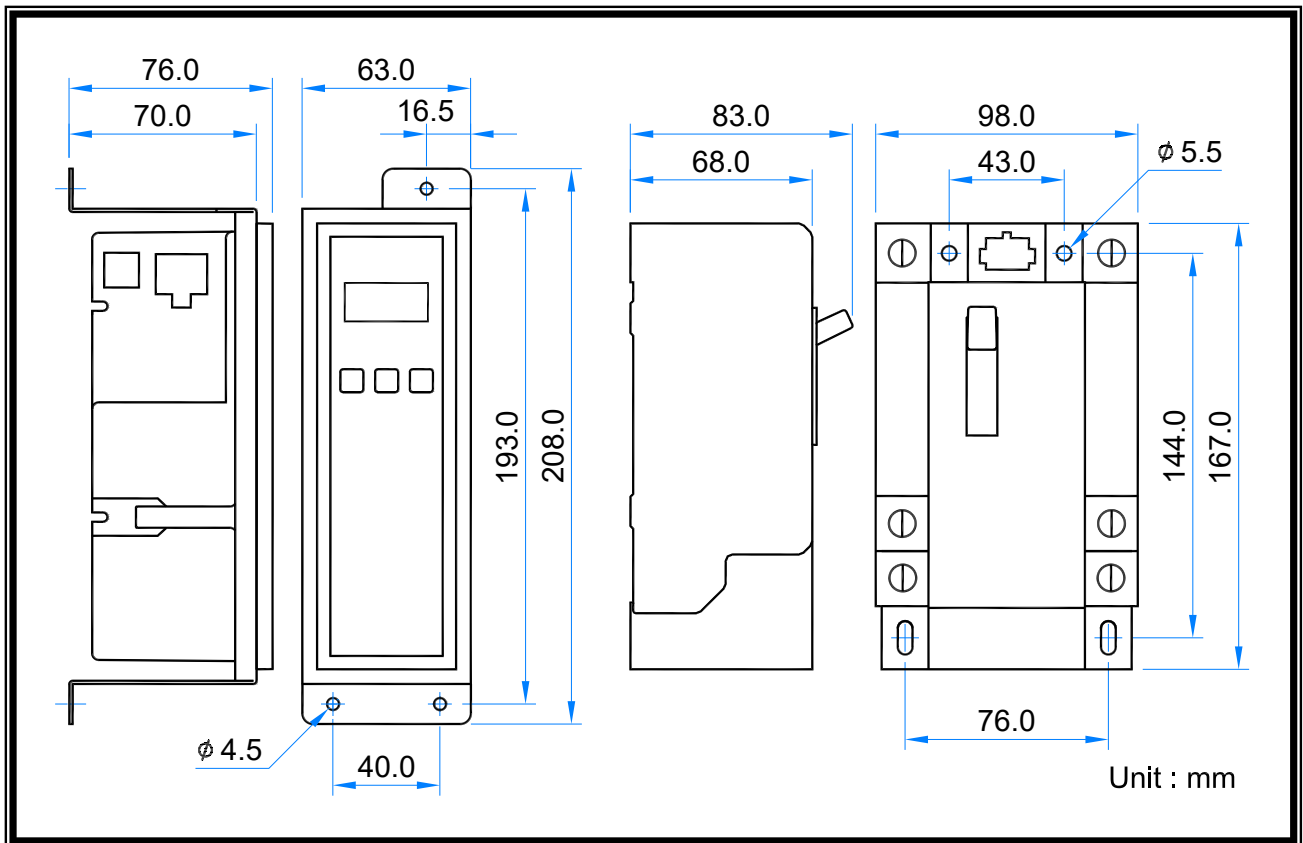

2.3 Panel Cut-Out for the TC-V2 (Unit : mm)

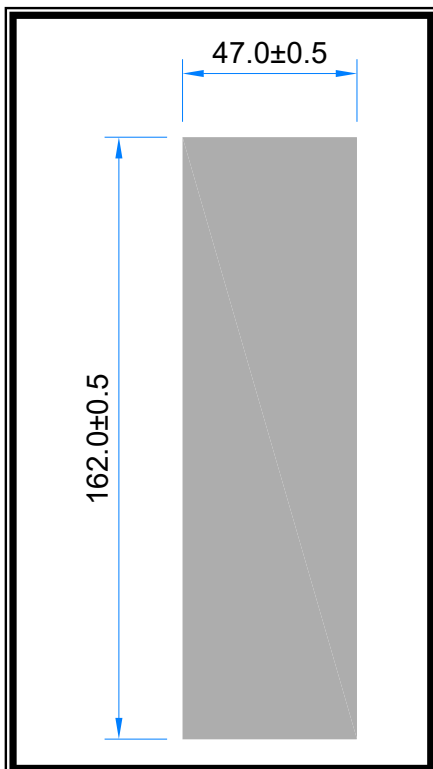

SECTION 3 : FUNCTION DESCRIPTION

3.1 General

Operation of the TCS2P125 electronic control.

3.2 TDNE Settings

TDNE provides a time delay when transferring from Normal to Emergency. Timing begins when the Emergency Source (generator) becomes available.

TDNE : Adjustable from 0 to 99 seconds.

3.3 TDEN Settings

TDEN provides a time delay when transferring from Emergency to Normal. This permits stabilization of the Normal Power before transferring back to normal. Timing begins when the Normal Power returns and becomes available and steady.

TDEN : Adjustable from 0 to 99 seconds.

3.4 TDEC Settings

TDEC timer keeps the generator running without load (Engine Cool-down) after the ATS transfer back to Normal Power. Timing begins when the transfer back to normal is completed.

TDEC : Engine Cool-down - from 0 to 99 sec.

3.5 TDES Setting

TDES is the time delay for Engine Start when the Normal Source voltage is in over or under-voltage (OV or UV). If power return to normal while timing, the TDES timer resets and starts again.

TDES : Adjustable from 0 to 30 seconds.

3.6 TD-OFF Setting

Time Delay on OFF this timer keeps the switch in the center neutral OFF position (completely disengaged) before transferring to the other side. You can preset the switch in Neutral or OFF from 0 to 18 seconds (Normally 2 to 3 sec).

TD-OFF : Adjustable from 1 to 20 seconds.

3.7 Plant Exerciser

This feature provides for automatic test operation of the generator. The interval is fixed at once per 1 to 4 weeks with a specific test day and time. The exerciser can be set for either testing with load or without load.

When the exerciser is activated the exerciser LED (EX) on the right side of display flashes and turns on during the exercise period.

3.8 Over / Under Voltage Sensing

The TC-V2 constantly monitors normal & emergency power. When power falls outside the programmed voltages this LED turns RED from GREEN and flashing to show OV / UV problems.

Adjustable over voltage range : 110 – 280 Vac

Over voltage reset : When voltage falls below 10 Vac of the OV setting.

Adjustable under voltage range : 80 – 230 Vac

Under voltage reset : When voltage exceeds 10 Vac of the UV setting.

3.9 Transfer Failure

When a transfer is made the TS125 communicates it's position to the TC-V2 controller by using two small internal micro-switches, if this signal is not received, it will try switching 3 more times every 2 seconds or until the connection is made. A flashing light indicator and a "FAIL" signal displayed an incomplete transfer and that the ATS mechanism or wiring is defective.

If the ATS fails, the TC-V2 controller stops all ATS functions and starts' flashing until the failure is corrected and the control is reset.

To reset the transfer fail alarm :

1. Manually move the ATS to the correct position.
2. Press any button (Auto, Program or Test) on the front panel to reset the alarm.

SECTION 4 : OPERATION

4.1 General

This section specifically describes the operation and functional use of the TC-V2 controller.

4.2 AUTO Mode

In AUTO the TC-V2 controller automatically transfer and retransfers from source to source as directed by the pre-programmed instructions.

In AUTO the controller monitors the condition of both normal and standby power sources providing the logic for the transfer operation.

4.3 TEST Mode

The TC-V2 is equipped with a test pushbutton that simulates the loss of normal source. Pushing the Test key the TC-V2 will execute a test on the ATS. The TDES and TDNE programmed time delays will be performed as part of the test. There are two test modes :

- Testing with load
- Testing without load

4.4 Programming Mode

The TC-V2 controller is fully programmable from the front panel when in the Program Mode. The build-in program buttons have multiple functions :

- Real time clock displaying
- Programming mode operating

To enter programming mode, push and hold **Program** button for 10 seconds. In the first 10 seconds the screen showing internal real time clock and then the word “ **Vr 1.0** ” will appears on the front display window for 2 seconds indicating the version of the software.

At this time start a line by line programming sequence. To advance to the next line, push the **Program** button on the front panel. To change each line's programming parameters, press the increase (\wedge) and decrease (\vee) buttons. When pressing and releasing the (\wedge) or (\vee) key the displayed parameter can be increased or decreased by one. The parameter will continue to scroll if the (\wedge) or (\vee) button is pressed and not released.

Always push the “ **Program** ” button to advance to the next line or until the word “ **End** ” appears on the screen. To immediately end the programming mode, you simply push the “ **Program** ” button for 4 seconds. Then the word “ **End** ” shows on the screen indicating the end of the programming mode.

If you like to return to factory settings, stay in programming mode and simultaneously press all 3 buttons (\wedge), (\vee) and **Program** buttons for 4 seconds. The TC-V2 will now automatically program itself to factory settings and the word “ **Au.Po** ” will appear on the display window.

4.5 AC Voltage Display Adjustment

The TC-V2 controller continually monitors normal & emergency power displaying volts and frequency on the front panel. (The voltage value is calibrated and adjusted at the factory). But when the ATS works on high capacitive or inductive loads the waveform distortion may cause the displayed to have slight differences from the users measuring instrument.

You can adjust the display value to equal to the users own instruments, by entering the setting mode to perform adjustment the parameter. Once the adjustment is completed, the voltage sensing value will increase or decrease according to the adjusted value and display it on the screen. The TC-V2 over and under voltage protection follow the adjusted value as the actual system voltage and perform the monitoring according to the new parameter.

See Table lines 2, 3, 4, 5 for voltage display setting.

4.6 Specification Summary

| ITEM | SPECIFICATION |
|------------------------|----------------------------------|
| Rated Voltage | 250 Vac |
| Rated Current | 125 Amp |
| Rated Frequency | 50/60 Hz |
| Poles | 2P |
| Switch Type | Double Throw |
| ATS Class | Class PC |
| Operation Life | Over 6000 Times W/L |
| Transfer Current | 3.0A @ 220 Vac 6.0A @ 110 Vac |
| Remote Start Contactor | 6A @ 277 Vac Max |
| N & E On Contactor | 7A @ 250 Vac Max |
| Power Consumption | < 1W |
| Operating Temperature | -20 to +60 °C |
| Storage Temperature | -20 to +80 °C |
| Operating Humidity | 0 to 95% |
| Weight | 1.8 kg +/- 2% |

4.7 System Setting Reference Table

| ITEM | DESCRIPTION | SETTING | | FACTORY SETTING |
|------|---|---|---------------|-----------------|
| 1 | Is this ATS operating in 1 Phase or 3 Phase? | 01 → 1 Phase | 02 → 3 Phase | 02 |
| 2 | Normal power VL12 voltage display adjustment setting | -99 – 99 V | | 00 |
| 3 | Normal power VL23 voltage display adjustment setting | -99 – 99 V | | 00 |
| 4 | Normal power VL31 voltage display adjustment setting | -99 – 99 V | | 00 |
| 5 | Emergency power VL12 voltage display adjustment setting | -99 – 99 V | | 00 |
| 6 | TDNE – Time Delay Normal to Emergency | 00 – 99 sec. | | 10 sec. |
| 7 | TDEN – Time Delay Emergency to Normal | 00 – 99 sec. | | 10 sec. |
| 8 | TDES – Time Delay Engine Start | 00 – 30 sec. | | 5 sec. |
| 9 | TDEC – Time Delay Engine Cool-down | 00 – 99 sec. | | 60 sec. |
| 10 | TD-OFF – Time Delay on OFF position | 01 – 20 sec. | | 5 sec. |
| 11 | Normal source over voltage setting | 11 – 28 (110 – 280V) | | 25 (250V) |
| 12 | Normal source under voltage setting | 08 – 23 (80 – 230V) | | 18 (180V) |
| 13 | Time delay if there is a problem with normal source voltage output | 00 – 99 sec. (0 = Without volt monitor function) | | 10 sec. |
| 14 | Standby source over voltage setting | 11 – 28 (110 – 280V) | | 25 (250V) |
| 15 | Standby source under voltage setting | 08 – 23 (80 – 230V) | | 18 (180V) |
| 16 | Time delay if there is a problem with standby source voltage output | 00 – 99 sec. (0 = Without volt monitor function) | | 10 sec. |
| 17 | Current day of week setting | 1 – 7 (Monday to Sunday) | | current |
| 18 | Current hour setting | 00 – 23 | | current |
| 19 | Current minute setting | 00 – 59 | | current |
| 20 | Plant exerciser test day of week | 1 – 7 (Monday to Sunday) | | 6 |
| 21 | Plant exerciser hour | 00 – 23 | | 12 |
| 22 | Engine run time on exerciser | 00 – 60 min (0 = Without exerciser function) | | 00 |
| 23 | Exerciser cycle | 01) Once a week 02) Once every 2 weeks 03) Once every 3 weeks 04) Once every 4 weeks | | 01 |
| 24 | Plant exerciser test with or without load | 01) Without load | 02) With load | 01 |
| 25 | Plant manual test with or without load | 01) Without load | 02) With load | 02 |

SECTION 5 : INSTALLATION INSTRUCTIONS

5.1 General

The TC-V2 controller is modular and is designed for installation next to switch or on the front door panel. A longer harness is required for door installation.

5.2 Installation On The Plate

STEP-1

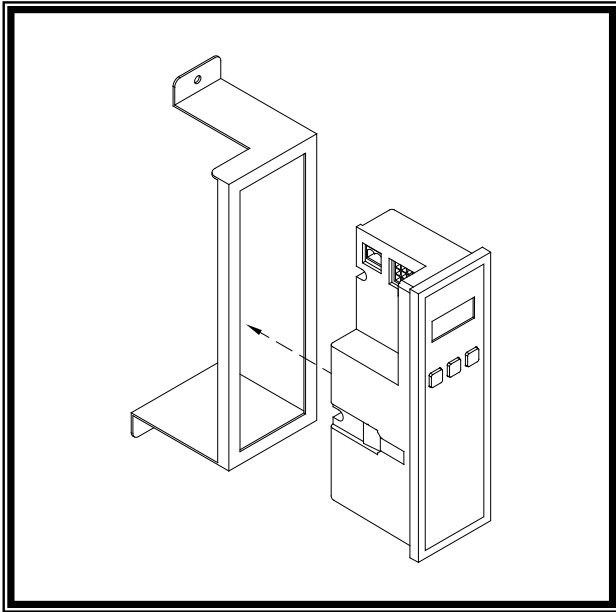

STEP-3

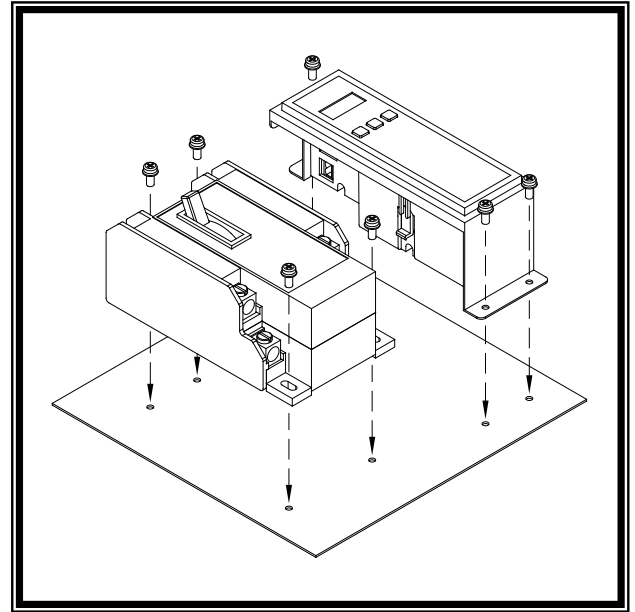

STEP-2

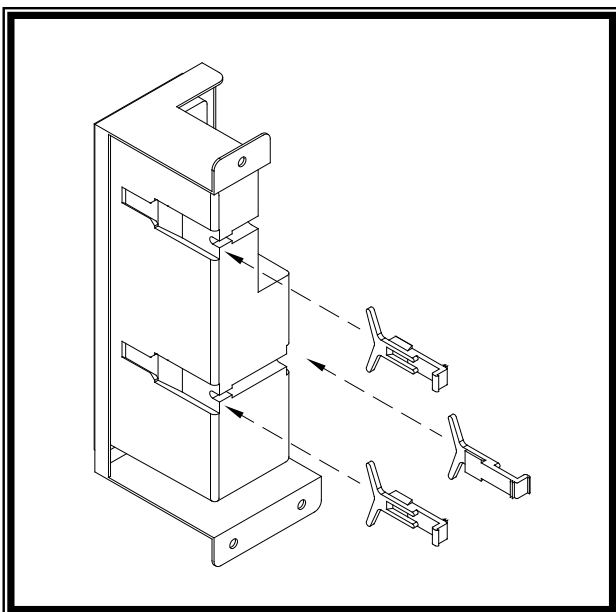

STEP-4

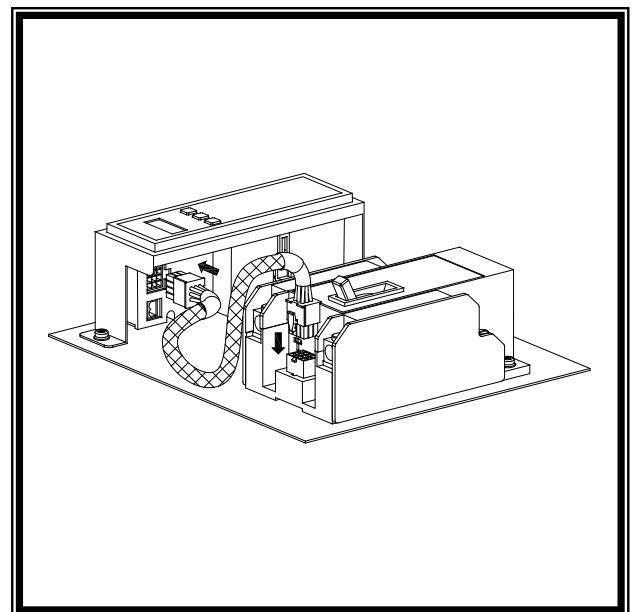

5.3 Installation On The Door Panel

STEP-1

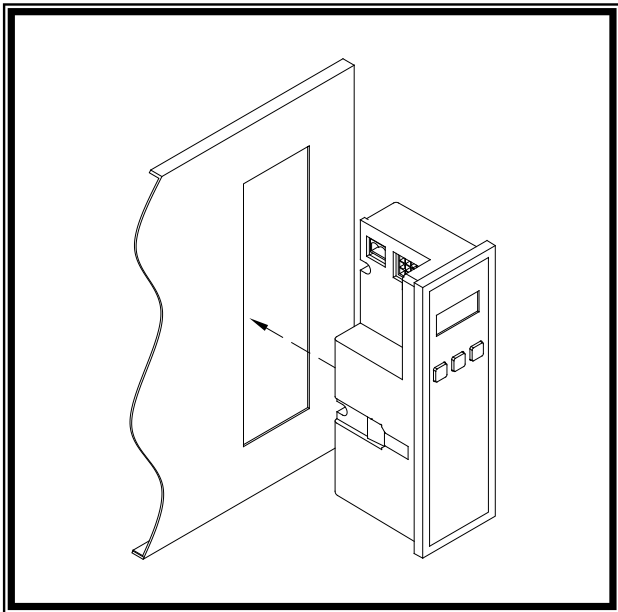

STEP-3

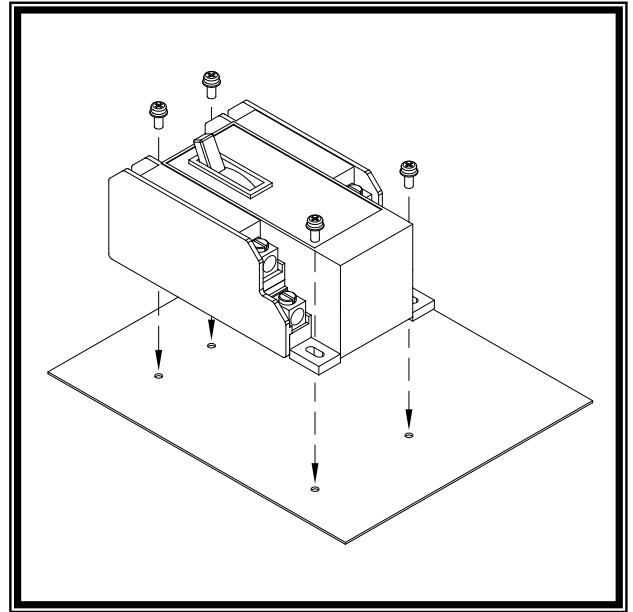

STEP-2

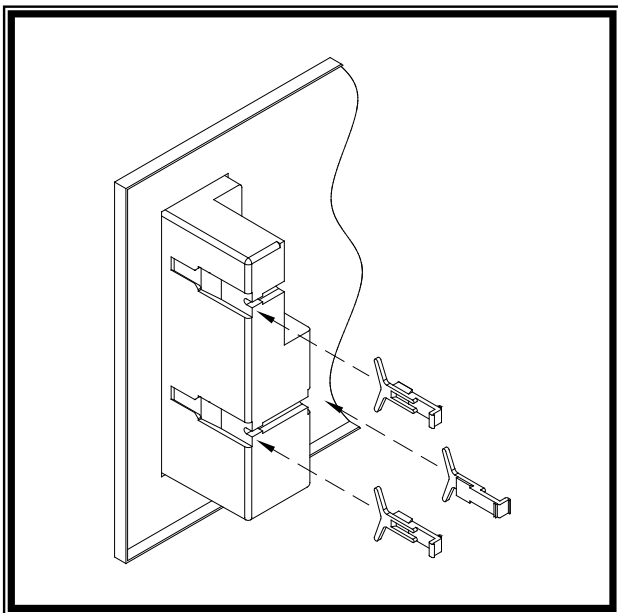

STEP-4

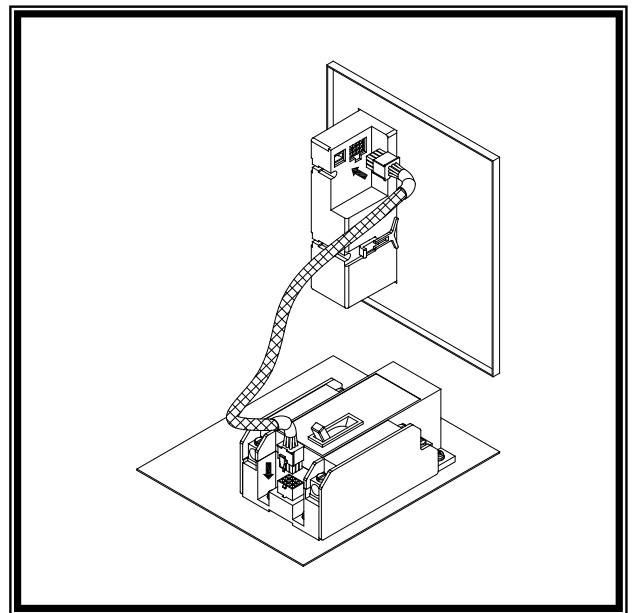

RECOMMENDED CABLE SIZES AND TORQUE VALUES

| Cable Size Unit : AWG or MCM (mm ²) | Tightening Torque Unit : lb. – in or N – m |
|---|--|
| 14-1/0 AWG (1.5 – 50 mm ²) | 51lb. – in (5.8 N – m) |

SECTION 6 : TYPICAL WIRING

6.1 TCS2P125 Standard Wiring Diagram (110 or 220V)

